

## **Eminox CO<sub>2</sub> whitepaper: Meeting the challenge of reducing CO<sub>2</sub> emissions – smart hybridisation and zero emissions**

### **Introduction**

The current European vehicle emissions legislation for trucks and buses (Euro VI) is focused on reducing particulate matter (PM) and nitrogen oxides (NO<sub>x</sub>). This has successfully reduced emissions of these substances but has not had a material impact on greenhouse gases (GHGs) such as carbon dioxide (CO<sub>2</sub>).

Consequently, the EU adopted the first ever CO<sub>2</sub> targets for road transport in 2019<sup>1</sup>. These mandate that manufacturers of new trucks and other heavy-duty vehicles will be required to cut CO<sub>2</sub> emissions by 15% on a fleet-wide average from 2025 and by 30% from 2030, compared with 2019 levels.

Alongside this, work began in 2020 on a post-Euro VI standard, which is expected to come into effect around 2025. This will mandate further, potentially challenging, reductions in NO<sub>x</sub> that will clearly need to be addressed in parallel with CO<sub>2</sub> targets, as well as introducing new targets for other species such as nitrogen dioxide (NO<sub>2</sub>). Similar legislation is planned in other regions across the globe as countries look to reduce CO<sub>2</sub> alongside other emissions.

However, manufacturers have already invested heavily in reducing CO<sub>2</sub> and NO<sub>x</sub> from existing engines. Speaking at an industry forum one manufacturer stated that the industry is currently within 10–15% of theoretical CO<sub>2</sub> engine efficiency for both passenger and heavy-duty diesel vehicles. System efficiency for NO<sub>x</sub> emissions reduction is greater than 90% when engines are up to operating temperature.

Essentially the biggest potential gains have already been made through proven exhaust aftertreatment technologies such as diesel oxidation catalysts, diesel particulate filters and selective catalytic reduction.

---

<sup>1</sup> Source: European Union [https://www.consilium.europa.eu/en/press/press-releases/2019/06/13/cutting-emissions-council-adopts-CO<sub>2</sub>-standards-for-trucks/](https://www.consilium.europa.eu/en/press/press-releases/2019/06/13/cutting-emissions-council-adopts-CO2-standards-for-trucks/)

Given these factors, how can OEMs and their suppliers overcome this challenge effectively and efficiently? This whitepaper sets out potential routes forward for heavy-duty OEMs in reducing CO<sub>2</sub> and meeting tightening targets by adopting a system-wide approach.

## The legislative roadmap

### On-Highway

Within Europe, the current Euro VI standard mandates strict limits for PM and NO<sub>x</sub> but has no target for CO<sub>2</sub>. On-highway vehicles need to achieve 460mg/kWh for NO<sub>x</sub> and 10 mg/kWh for PM over the World Harmonised Transient Cycle (WHTC) in order to comply. While all new vehicles meet the standard, with more and more Clean Air Zones and Ultra Low Emissions Zones appearing across the UK and Europe, operators of older trucks, buses and coaches have therefore looked to retrofit emissions reduction technologies to cost-effectively achieve compliance.

### On-Highway Legislation Roadmap

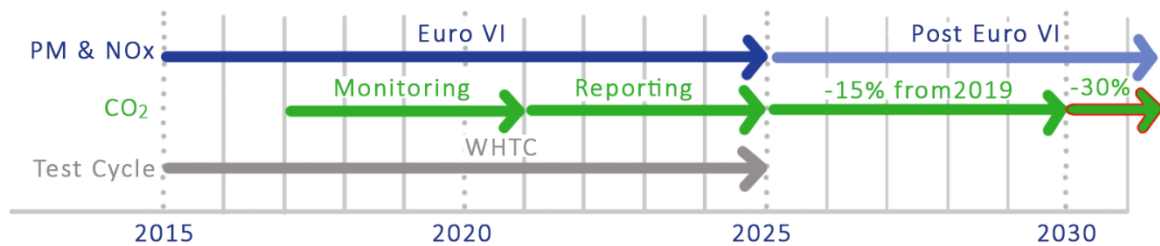

The near future will see major changes in legislation, driven by the need to reduce emissions and GHGs to meet climate change and decarbonisation targets and to improve air quality. Post-Euro VI regulations are currently being planned but are expected to further reduce NO<sub>x</sub> limits as well as introducing NO<sub>2</sub> targets.

Alongside this, separate legislation will force a reduction of 15% in CO<sub>2</sub> by 2025, rising to 30% from 2030, compared to 2019 levels. These will be reviewed in 2022, and while the current COVID crisis has caused some to question whether targets should be delayed it is likely that they will be retained given other EU decarbonisation commitments.

### Off-Highway

Heavy-duty Non-Road Mobile Machinery (NRMM) manufacturers have had to meet EU Stage V regulations, introduced from 2019, which are expected to remain in force until 2027. Their replacement is likely to include a target of at least 50% reduction in NO<sub>x</sub> whilst maintaining PM at current levels.

## Off-Highway Legislation Roadmap

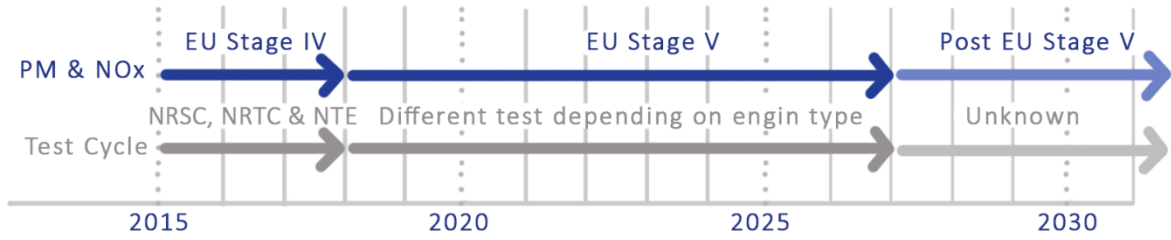

Given the smaller volumes of individual vehicles/construction equipment produced compared to trucks and buses, meeting yet tighter emissions standards will be a particular challenge. Manufacturers will need to make significant investment in engines to ensure compliance, which will not be cost-effective for some variants. Consequently, many are rationalising their range, focusing on those engines where the benefits and market opportunity of developing and homologating bespoke emissions control systems, potentially with external partners, outweighs the costs.

### Solutions for future compliance

The typical layout of a Euro VI or Stage V Exhaust Aftertreatment Systems (EATS) is shown in this graphic.

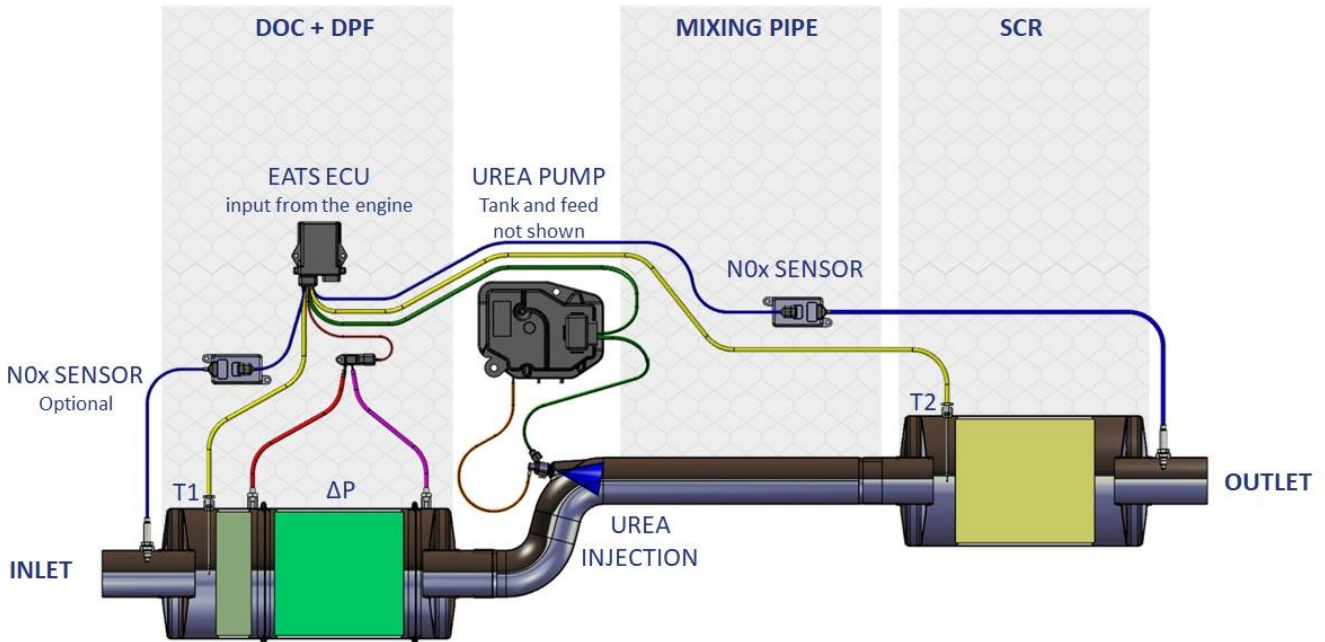

The EATS employ technologies such as a Diesel Oxidation Catalyst and Diesel Particulate Filter for PM regulation and a Selective Catalytic Reduction Catalyst for NOx control, as outlined below:

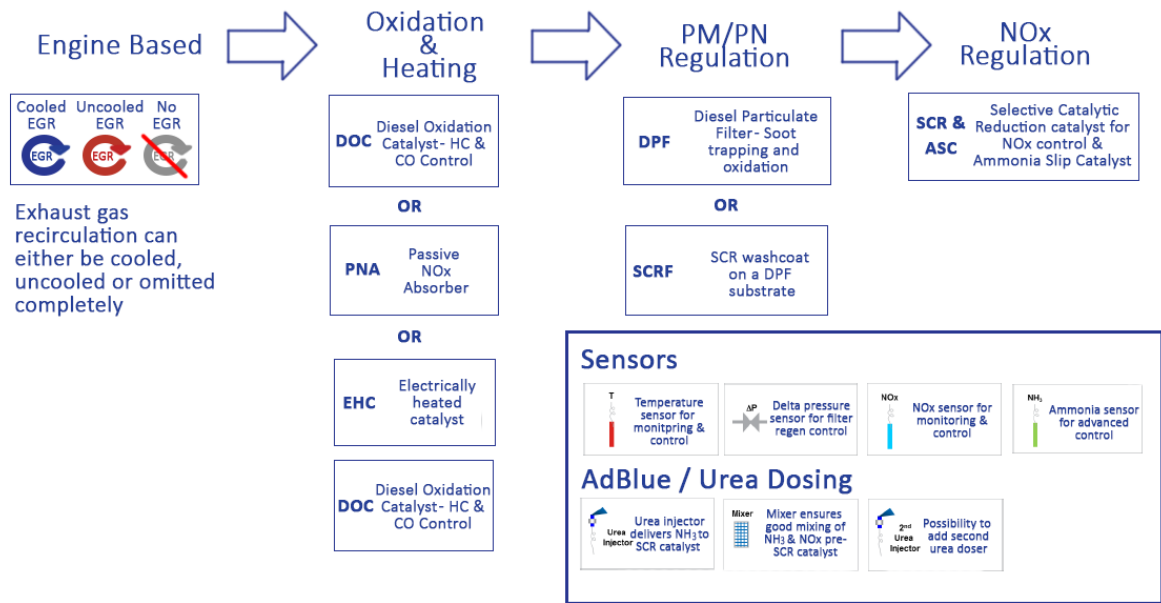

However, given tightening legislative targets, improving performance in reducing emissions, particularly around CO<sub>2</sub>, requires a different approach. Future solutions need to focus on three areas – engine development, transforming the EATS and wider changes to the powertrain/fuels, with improvements in all three enabling compliance.

## 1. Engine Development

Engine and vehicle manufacturers will utilise strategies including cylinder deactivation, engine downspeeding and engine downsizing to maximise fuel efficiency and therefore, reduce CO<sub>2</sub> emissions. In addition, technologies such as variable speed water and oil pumps and electrical driven engine auxiliaries could be employed to further reduce unnecessary parasitic load on the engine. In combination, with the overall target of reducing CO<sub>2</sub> emissions, the improvements made to engine systems are likely to result in reduced exhaust temperature, which could detrimentally affect the EATS performance.

## 2. Transforming the EATS

Ever-decreasing emissions targets coupled with CO<sub>2</sub> reduction goals puts additional strain on the aftertreatment to perform better over a broader range of operating conditions. A traditional aftertreatment layout, DOC, DPF and SCR/ASC is unlikely to satisfy the requirement for NO<sub>x</sub> reduction and therefore the EATS architecture must be adapted. Dual SCR with an upstream close coupled module to maximise the exhaust energy directly from the engine is clearly an option to enable a

broader NOx control window. SCR coated particulate filters will reduce the EATS size whilst minimising thermal lag traditionally caused by the DPF.

The introduction of hybrid powertrains is going to require package space to accommodate the batteries, which will mean the EATS has to be more compact and deliver greater efficiency, leading to a focus on expert design and packaging, whilst utilising more intelligent software to control performance across the range of engine operating parameters.

Dependent on the overall architecture, other technologies such as electrically heated catalysts, passive NOx absorbers and urea hydrolysis catalysts could be employed to maximise the operating range of the aftertreatment. Whatever the layout of the engine and aftertreatment system the effective use of thermal insulation will be a significant enabler to meeting emissions targets.

### **3. Powertrain**

The automotive industry is clearly on a path to a zero-emissions future and heavy-duty vehicles are no exception. The future for the heavy-duty diesel powertrain is going to involve hybrid engine-battery powertrains in various architectures from electric assist in mild hybrids to series hybrids with an electric drivetrain with an engine providing power to the battery. The introduction of hybrids as a heavy-duty powertrain solution will, due to the space required for the batteries, necessitate the downsizing of both the engine and the EATS.

While fossil-derived diesel is currently the predominant fuel for heavy-duty vehicles, decarbonising fuels will bring well-to-wheel reductions in CO<sub>2</sub>. There is also a need to decarbonise the generation of electric power, removing the burning of fossil fuels from power stations if targets are to be made for creating truly clean power. Alternative fuel options available will vary across industry, including:

- Road transport: Alternative fuels created as by-products from other processes: LPG, propane, methanol, etc.
- Agriculture: Biomethane from anaerobic digestion
- Marine: LNG as an interim solution, followed by hydrogen in the future
- Aviation: Fuels from solid waste feedstock

#### **Box out: Eminox and biofuels from waste**

Eminox, in collaboration with JM Davy, has developed an engineered solution to package Fischer-Tropsch catalyst material within a novel reactor technology that Johnson Matthey and BP have jointly

developed. This is being used in the US at the world's first plant to manufacture renewable aviation fuels from municipal solid waste feedstock, or household rubbish that would otherwise be landfilled. Able to operate at both large and small scale, the technology economically converts synthesis gas into long-chain hydrocarbons suitable for the production of diesel and jet fuels.

What is clear is that there are multiple options for reducing CO<sub>2</sub> and NO<sub>x</sub> and that different OEMs will have different approaches, depending on their needs and applications. Selecting and implementing the optimal solution will require an integrated approach, based on a combination of experience, expertise and deep understanding of emissions reduction.

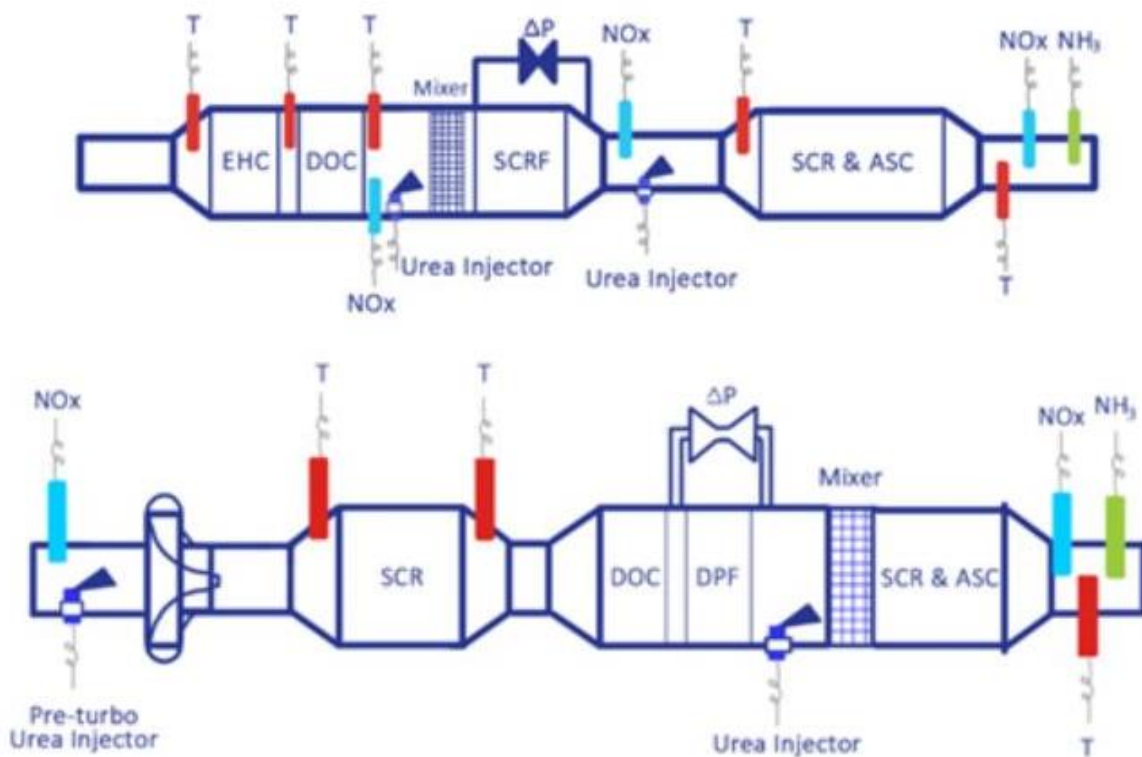

### Eminox – your emissions reduction partner

Eminox has built up over 30 years of experience in EATS across multiple heavy-duty industries, including on-highway (buses, trucks, coaches), off-highway, rail, marine and aviation. We partner with leading OEMs, including Volvo, Iveco and Liebherr, as well as designing and manufacturing retrofit solutions for buses, coaches and trucks.

We are specialists in the design and manufacture of EATS that are packaged to meet specific vehicle needs, in both diesel and dual-fuel powertrains. To ensure we meet the needs of our global OEM customer base, we are continually investing in our capabilities, including our state-of-the-art facilities, which are accredited to the IATF 16949:2016 global automotive standard. We provide a full solution, from design through prototyping to manufacture, with in-house skills in 3D design, computational fluid dynamics (CFD) and finite element analysis (FEA).

Over the course of our work as the customer development partner for many world-class manufacturers of heavy-duty vehicles we have built up a strong understanding of complex EATS technologies and techniques such as reductant dosing, ensuring the creation of well-packaged solutions that aid emissions compliance.

Through our experience and capabilities, we offer complete, integrated solutions. We take a whole system approach, bringing together hardware and software, combining our experience in EATS with our in-house strengths in intelligent SCR control software. This enables us to create solutions tailored to individual OEM requirements, delivered to the tightest timescales across the globe.

### **Conclusion**

Reducing CO<sub>2</sub> emissions is a key priority for governments looking to meet GHG goals, leading to stricter legislation worldwide. Additionally, CO<sub>2</sub> emissions need to be managed in tandem with other emissions, such as NO<sub>x</sub>, as they interact closely. Given the stringent targets being set and limited opportunity for transformative improvement in existing individual technology areas, this brings major challenges for OEMs.

To meet emissions standards for CO<sub>2</sub>, OEMs need to take a wider, whole-system approach, especially hybridisation, more advanced EATS and intelligent control software to cost-effectively ensure compliance.

Operating globally for over 40 years, Eminox is the perfect partner to help OEMs reduce emissions – whether on-highway, off-highway or in other sectors (rail, marine, aviation). Contact us to find out how we can help you meet your emissions challenges.